

# SG-215M6

## SOLAR PANEL

### Industry leading warranties:

- Performance warranty of 90% power output after 12 years and 85% power output after 25 years
- Power tolerance warranty of +5%, -0%
- Parts and workmanship warranty of 10 years

Please refer to our website for full details on our warranty terms and conditions

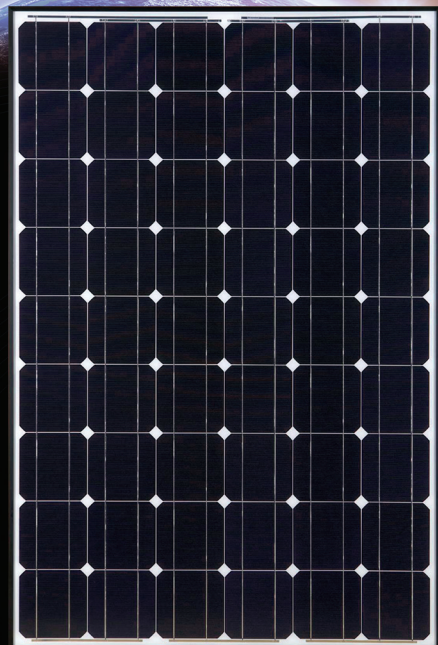

## Sungrid is an Australian solar energy company.

Our high quality solar panels are manufactured and supplied to customers around Australia, New Zealand and the UK. Only the best quality components, sourced from leading suppliers, go into the finished Sungrid product which means we are able to provide peace of mind with our industry-leading warranties.

Combining 40 years of extensive international experience and knowledge of the renewable energy industry, the development experts at Sungrid are continually improving the economic efficiency of our solar panels to consistently deliver a great value proposition for our customers.

The manufacturing facilities we have chosen maintain internationally-accredited quality assurance processes. This provides us, and our customers, with a high level of confidence in the quality of our products and the facilities in which they are made.

Our products are supported by our warranties. The length of the warranty is a direct reflection of the confidence a producer has in its own product. Sungrid has absolute confidence in its quality control methods and that's why the warranties that Sungrid provide are amongst the best in the marketplace.



# SG-215M6 Photovoltaic module

## SG-215M6 Technical specifications:

Electrical characteristics	
	<sup>1</sup> STC
Maximum power (W)	215
Open circuit voltage (V)	33.80
Short circuit current (A)	8.30
Maximum power voltage (V)	28.10
Maximum power current (A)	7.70
Module efficiency (%)	14.2

<sup>1</sup>STC: 1000W/m<sup>2</sup>, AM 1.5, 25 °C

<sup>2</sup> NOCT (°C)	48
Nominal voltage (VDC)	18
Power tolerance (%)	+5, -0
Temperature coefficient of Isc (%/°C)	+0.05
Temperature coefficient of Voc (%/°C)	-0.35
Temperature coefficient of power (%/°C)	-0.54
Series fuse rating (A)	15
Maximum system voltage (Vdc)	1000
Operating temperature (°C)	-40/+85
Number of bypass diodes	3

<sup>2</sup>NOCT: 800W/m<sup>2</sup>, air temperature 20 °C, wind speed 1 m/s.

Mechanical and physical characteristics	
Cells	54 pcs (6x9) 156x156 mm / mono
Weight (kg)	18.5
Dimensions (L x W x D mm)	1483 x 995 x 50
Frame colour	Black
Maximum load (wind/snow)	5400Pa (to IEC61215 Ed.2)
Cable size (area, length mm)	4 mm <sup>2</sup> , 1000mm
Connector type	Tyco
Product code	SG-215M6

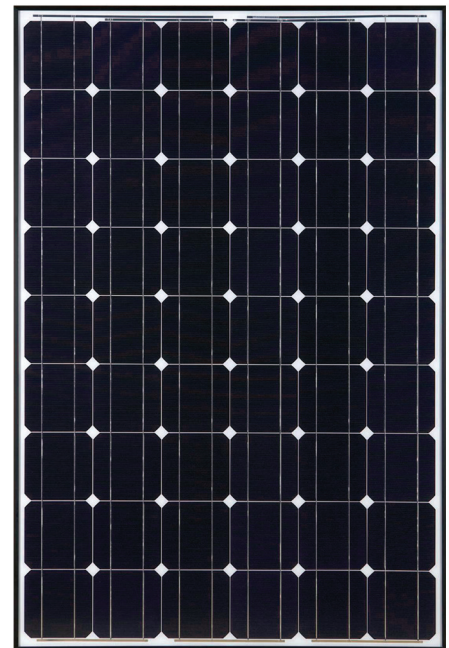

SG-215M6

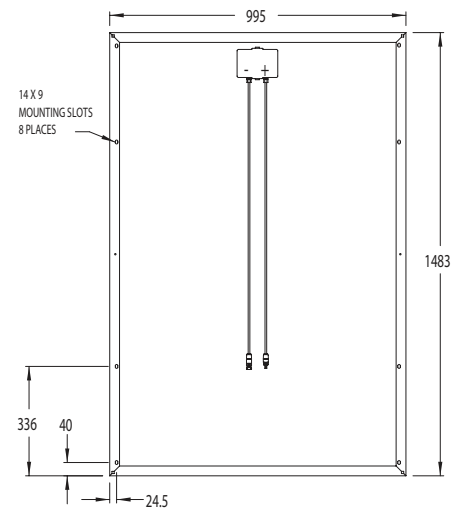

SG-215M6 Diagram



[www.sungridsolar.com](http://www.sungridsolar.com)

Please refer to our website for full details on our warranty terms and conditions.

Specifications may be subject to change without notice. Information correct at time of going to print (11.01.11)



Sungrid products are available from:



Address: Moor Hall, Sandhaves Hill,  
East Grinstead, West Sussex, RH19 3NR

Tel: 01342 871616

Website: [www.solaradvancedsystems.co.uk](http://www.solaradvancedsystems.co.uk)

Email: [sales@solaradvancedsystems.co.uk](mailto:sales@solaradvancedsystems.co.uk)